

# SINEAX TV 819, 1 channel Isolating amplifier unipolar/bipolar

**For electrically insulating, amplifying and converting DC signals**



## Application

The purpose of the active isolating amplifier **SINEAX TV 819** (Fig. 1 and 2) is to electrically insulate input and output signals, respectively to amplify and/or change the signal level or type (current or voltage) of the input signals.

The compact SINEAX TV 819 provides a large selection of input and output ranges that can be configured by the user with soldered jumpers and potentiometers.

The amplifier fulfils all the important requirements and regulations concerning electromagnetic compatibility **EMC** and **Safety** (IEC 1010 resp. EN 61 010). It was developed and is manufactured and tested in strict accordance with the **quality assurance standard** ISO 9001.



Fig. 1. Isolating amplifier SINEAX TV 819 in housing **P12/17**, terminals not pluggable.

## Features / Benefits

- Electric insulation between input, output 3.7 kV and power supply 3.7 kV / Prevents measurement errors due to potential leakage
- Flexibility provided by more than 250 different input and output combinations selected by simply positioning soldered jumpers / Reduced stocking
- Non-standard user-specific ranges available
- Wide DC, AC power pack tolerance / Universal
- Mounting of the isolating amplifier on a top-hat rail
- Housing only 17.5 mm / Low space requirement



Fig. 2. Isolating amplifier SINEAX TV 819 in housing **P12/17 St**, terminals pluggable.

## Standard versions

Input and output set to 4...20 mA. Any of the standard ranges given in the Section “Technical data, measuring inputs” are simply selected by positioning soldered jumpers. The fine adjustment is accomplished using the potentiometers “Zero” and “Span”. It is only necessary to quote the **Order No.:**

**Tabelle 1: Standard-Ausführung**

Standard range Input	Standard range Output	Power supply	Screw terminals	Order Code	Order No.
4 ... 20 mA	4 ... 20 mA	24... 60 V DC/AC	not pluggable	819 - 311	146 838
		85 ... 230 V DC/AC		819 - 321	146 846
		24 ... 60 V DC/AC	pluggable	819 - 911	146 854
		85 ... 230 V DC/AC		819 - 921	146 862

Please complete the Order Code 819 – .... according to “Table 3: Ordering information” for versions with user-specific input and/or output ranges.

# SINEAX TV 819, 1 channel

## Isolating amplifier unipolar/bipolar

### Technical data

#### Measuring input $\rightarrow$

##### DC current:

Limit values  
 0...0.1 to 0...40 mA  
 also live-zero,  
 start value > 0 to  $\leq 50\%$  final value  
 or span 0.1 to 40 mA  
 between -40 and 40 mA  
 (also bipolar asymmetrical)

##### DC voltage:

Limit values  
 0...0.06 to 0...1000 V  
 also live zero,  
 start value > 0 to  $\leq 50\%$  final value  
 or  
 span 0.06 to 1000 V  
 between -1000 and 1000 V  
 (also bipolar asymmetrical)

##### Overload capacity:

DC current  
 continuously 2-fold  
 DC voltage  
 continuously 2-fold

#### Measuring output $\rightarrow$

##### DC current:

Standard ranges  
 0...20 mA, 4...20 mA,  $\pm 20$  mA  
 Limit values  
 0...1 to 0...20 mA  
 0.2...1 to 4...20 mA  
 -1...0...+1 to -20...0...+20 mA

##### Burden voltage:

12 V

##### External resistance:

$R_{\text{ext max.}} [\text{k}\Omega] = \frac{12 \text{ V}}{I_{\text{AN}} [\text{mA}]}$   
 $I_{\text{AN}}$  = Output circuit full-scale value

##### DC voltage:

Standard ranges  
 0...10 V, 2...10 V,  $\pm 10$  V  
 Limit values  
 0...1 to 0...10 V  
 0.2...1 to 2...10 V  
 -1...0...+1 to -10...0...+10 V

##### Burden:

$R_{\text{ext min.}} [\text{k}\Omega] \geq \frac{U_{\text{AN}} [\text{V}]}{5 \text{ mA}}$   
 $U_{\text{AN}}$  = Output circuit full-scale value

##### Current limiter at

$R_{\text{ext max.}}$ :

Approx.  $1.1 \times I_{\text{AN}}$  for current output

##### Voltage limiter at

$R_{\text{ext}} = \infty$ :

Approx. 13 V

Residual ripple in  
 output current: < 0.5% p.p.

Response time: < 100 ms

#### Power supply $\rightarrow$

DC, AC power pack (DC or 45...400 Hz)

**Table 2: Nominal voltages and tolerances**

Nominal voltage $U_N$	Tolerance
24 ... 60 V DC / AC	DC - 15 ... + 33%
85 ... 230 V DC / AC	AC $\pm 15\%$

Power input:  $\leq 1.5 \text{ W resp. } \leq 3 \text{ VA}$

#### Accuracy data (acc. to EN/IEC 60 770-1)

Basic accuracy: Limit error  $\leq \pm 0.2\%$   
 including linearity and reproducibility errors

#### Reference conditions:

Ambient temperature: 23 °C,  $\pm 2 \text{ K}$   
 Power supply: 24 VDC  $\pm 10\%$  and 230 VAC  $\pm 10\%$   
 Output burden: Current:  $0.5 \cdot R_{\text{ext max.}}$   
 Voltage:  $2 \cdot R_{\text{ext min.}}$

#### Influencing factors:

Temperature:  $< \pm 0.1\%$  per 10 K  
 Burden influence:  $< \pm 0.1\%$  for current output  
 $< \pm 0.2\%$  for voltage output  
 if  $R_{\text{ext}} < 2 \cdot R_{\text{ext min.}}$   
 Longtime drift:  $< \pm 0.3\%$  / 12 months  
 Switch-on drift:  $< \pm 0.2\%$   
 Common and transverse mode influence:  $< \pm 0.2\%$   
 Output + or - connected to ground:  $< \pm 0.2\%$

#### Installation data

Mechanical design: Housing **P12/17** and **P12/17 St**  
 See section "Dimensional drawings" for dimensions  
 Material of housing: Lexan 940 (polycarbonate)  
 flammability class V-0 acc. to UL 94,  
 self-extinguishing, non-dripping, free of halogen  
 Mounting: For snapping onto top-hat rail  
 (35 x 15 mm or 35 x 7.5 mm) acc. to EN 50 022  
 Position of use: Any  
 Electrical terminals (fixed or pluggable): PHOENIX screw terminals with wire guards, for 0.14 mm<sup>2</sup> to 2.5 mm<sup>2</sup>

Weight: Approx. 0.1 kg

**Electrical insulation:** All circuits (measuring inputs / measuring outputs / power supply) are electrically insulated

**Regulations**

Electromagnetic compatibility: The standards EN 50 081-2 and EN 50 082-2 are observed

Protection (acc. to IEC 529 resp. EN 60 529): Housing IP 40  
Terminals IP 20

Electrical standards: Acc. to IEC 1010 resp. EN 61 010

**Permissible operating voltages acc. to EN 61 010-1**

Increased isolation, contamination level 2, overvoltage category II, to 2000 m above sea level

	Input	Output
Power supply	1000 V	300 V
Input		600 V (1000 V)*

\* Values in brackets are valid for overvoltage category I

**Test Voltages AC / 50 Hz / 1 minute**

	Input	Output
Power supply	3700 V	3700 V
Input		3700 V

**Ambient tests**

EN 60 068-2-6: Vibration

Acceleration: ± 2 g

Frequency range: 10 ... 150 ... 10 Hz, rate of frequency sweep: 1 octave/minute

Number of cycles: 10, in each of the three axes

EN 60 068-2-27: Shock

Acceleration: 3 x 50 g,  
3 shocks each in 6 directions

EN 60 068-2-1/-2/-3: Cold, dry heat, damp heat

**Environmental conditions**

Commissioning temperature: - 10 to + 55 °C

Operating temperature: - 25 to + 55 °C

Storage temperature: - 40 to + 70 °C

Annual mean relative humidity: ≤ 75%

Altitude: 2000 m max.

Indoor use statement!

**Table 3: Ordering information**

(see also Table 1: "Standard versions")

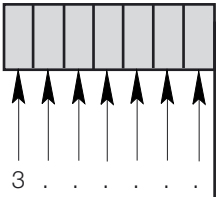
Order Code <b>819</b> -	
Features, Selection	
<b>1. Mechanical design</b>	
3) Housing P12/17 for rail mounting, screw terminals not pluggable	3 . . . . .
9) Housing P12/17 St for rail mounting, screw terminals pluggable	9 . . . . .
<b>2. Version / Power supply</b>	
1) Standard, 24 ... 60 V DC/AC	. 1 . . . . .
2) Standard, 85 ... 230 V DC/AC	. 2 . . . . .
<b>3. Function</b>	
1) 1 input max. 1000 V, 1 electrically insulated output	. . 1 . . . . .
<b>4. Input signal</b>	
9) Input [V]	. . . 9 . . .
Z) Input [mA]	. . . Z . . .
Line 9: [V] 0 ... 0.06 to 0 ... 1000, also live-zero, start value > 0 to 50% final value or span 0.06 to 1000 V between - 1000 and 1000 also bipolar asymmetrical.	
Line Z: [mA] 0 ... 0.1 to 0 ... 40; also live-zero, start value > 0 to 50% final value, or span 0.1 to 40 mA between - 40 and 40 mA, also bipolar asymmetrical.	
<b>5. Output signal</b>	
9) Output [V]	. . . . 9 . .
Z) Output [mA]	. . . . Z . .
Line 9: [V] 0 ... 1 to 0 ... 10, 0.2 ... 1 to 2 ... 10 - 1 ... 0 ... + 1 to -10 ... 0 ... + 10	
Line Z: [mA] 0 ... 1 to 0 ... 20 0.2 ... 1 to 4 ... 20 - 1 ... 0 ... + 1 to -20 ... 0 ... + 20	
<b>6. Output characteristic</b>	
0) Standard (directly proportional, 0...Y / 0,2Y...Y / -Y...0...+Y)	. . . . . 0 .
1) Inversely proportional, Y...0 / Y...0,2Y / +Y...0...-Y)	. . . . . 1 .
<b>7. Test certificate</b>	
0) Without test certificate	. . . . . 0
D) Test certificate in German	. . . . . D
E) Test certificate in English	. . . . . E

Y = Output circuit full-scale value

# SINEAX TV 819, 1 channel

## Isolating amplifier unipolar/bipolar

### Dimensional drawings

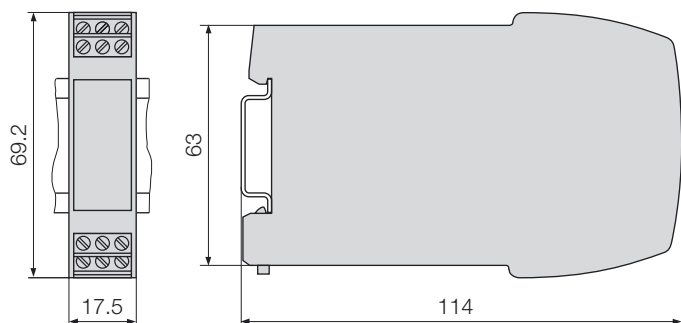

Fig. 3. SINEAX TV 819 in carrying rail housing **P12/17** clipped onto a top-hat rail (35 × 15 mm or 35 × 7.5 mm, acc. to EN 50 022), screw terminals not pluggable.

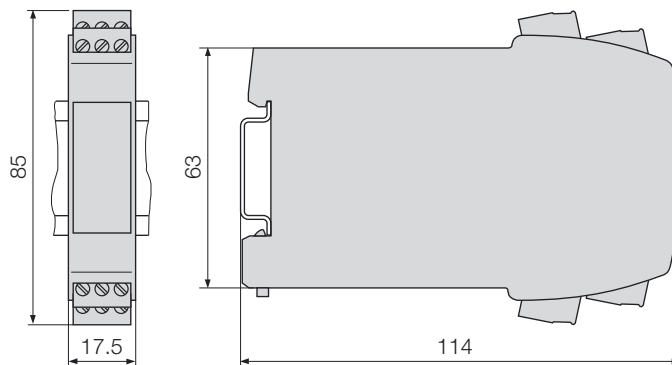

Fig. 4. SINEAX TV 819 in carrying rail housing **P12/17 St** clipped onto a top-hat rail (35 × 15 mm or 35 × 7.5 mm, acc. to EN 50 022), screw terminals pluggable.

### Standard accessories

1 Operating Instructions in German, French and English

### Electrical connections

Measuring function / application	DC voltage (direct input)	DC current	DC voltage (input via potential divider)
Measuring span	0.06 ... 40 V	0.1 ... 40 mA	> 40 ... 1000 V
Measuring range limits taking account of the max. measuring span	- 40 ... 0 ... 40 V	- 40 ... 0 ... 40 mA	- 1000 ... 0 ... 1000 V
Electrical connections			

Subject to change without notice • Edition 12.05 • Data sheet TV 819 Le

Camille Bauer LTD  
 Aargauerstrasse 7  
 CH-5610 Wohlen/Switzerland  
 Phone +41 56 618 21 11  
 Fax +41 56 618 35 35  
 e-mail: info@camillebauer.com  
 http://www.camillebauer.com