

KINAX 2W2

Programmable Transmitter for Angular Position

Application

The **KINAX 2W2** (Figs. 2 and 3) converts the angular position of a shaft into a **load independent** direct current signal, proportional to the angular position. The unit is **contact free** and has **minimal mechanical abrasion** on the input shaft. It technically extends the delivery program of angular transmitters with a programmable version and thus creates a number of new technical application possibilities.

Features / Benefits

- Measuring range, sense of rotation, characteristic, switching point and other additional functions programmed using PC / Simplifies project planning and engineering, short delivery times, low stocking

Measured variable	Measuring range limits
Angular position	Programmable between 0 ... 10 and 0 ... 50 or 0 ... 50 and 0 ... 350 \angle °

- Type of protection "Intrinsic safety" EEx ia IIC T6 / Can be mounted within the hazardous area (see "Table 3: Data on explosion protection")
- Simulation of measured values / The testing of the subsequent device chain is already possible during the installation phase
- Measured value acquisition / Display of the instantaneous value and a trend graph of the measured value on the screen
- Adjustment / Independent fine adjustment of the analog output, zero position and measuring range
- Characteristic of the output value / Programmable as a linear, V-characteristic, or any characteristic curve
- The shaft can be turned through full
- Patented measuring method

Layout and mode of operation

The transmitter consists of 2 main parts: the differential screen capacitor D and the electronic circuitry E (see Fig. 1).

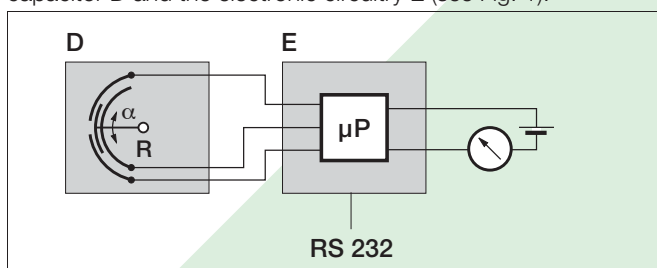

Fig. 1. Block diagram.

The angular deflection α of the device to be measured is transferred to the rotor R of the differential screen capacitor with the aid of a mechanical coupling. It is then converted into a change of capacitance proportional to the angle.

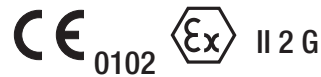

Fig. 2. KINAX 2W2 with shaft dia. 2 mm, length 6 mm.



Fig. 3. Rear view with programming connector and connections for measuring output.

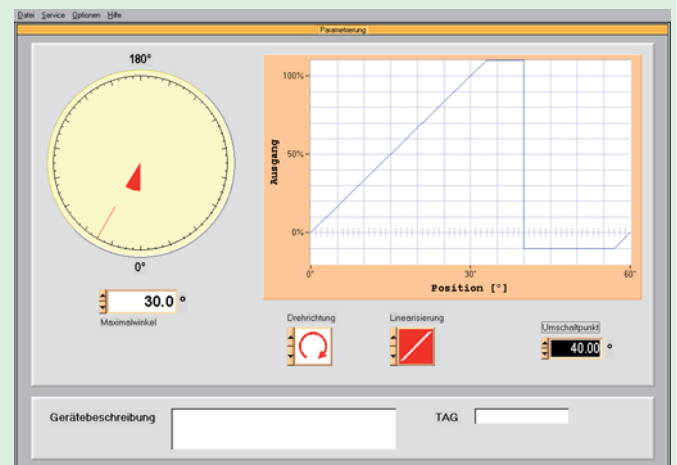

Fig. 4. Print screen example of the menu-controlled programming software.

All changes to the position of the rotor result in a change in the capacitance at the input to the microprocessor. This is transformed into a DC current signal proportional to the measured value.

KINAX 2W2

Programmable Transmitter for Angular Position

Programming

A PC, the programming cable PK 610 plus ancillary cable and the configuration software 2W2 are required to program the transmitter. (Details of the programming cable and the software are to be found in the separate data sheet: PK 610 Le.)

The connection between "PC ↔ PK 610 ↔ KINAX 2W2" can be seen from Fig. 5. The transmitter can be programmed either with or without the power supply connected.

The software 2W2 is supplied on one CD and runs under Windows 95 or higher.

The programming cable PK 610 adjusts the signal level between the PC and the transmitter KINAX 2W2.

The programming cable PK 610 is used for programming both standard and Ex versions.

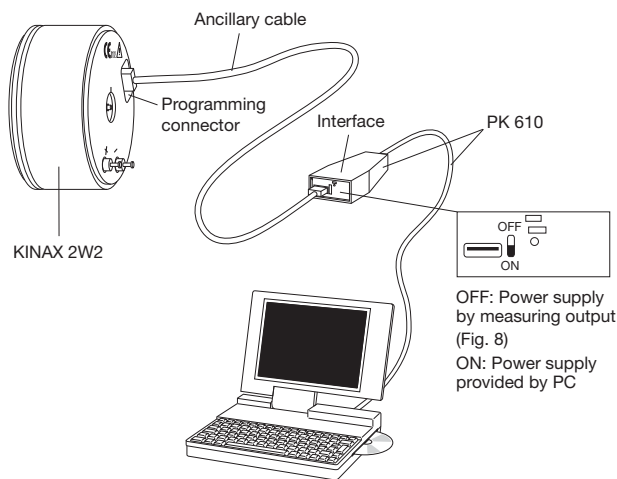

Fig. 5. Example of the set-up for programming a KINAX 2W2 without the power supply. For this case the switch on the interface must be set to "ON".

Technical data

General

Measured quantity: Angle of rotation α \curvearrowright °
 Measuring principle: Capacitive method
 Differential screen capacitor with contact-free, non-wearing positional pick-up. Drive shaft fully rotatable without stops (patented measuring method)

Measuring input

Measuring range of rotation angle: Programmable between 0 ... 10 and 0 ... 50 or 0 ... 50 and 0 ... 350 \curvearrowright °
 Drive shaft diameters: 2 or 6 mm resp. 1/4"
 Frictional torque: < 0.001 Ncm with shaft dia. 2 mm < 0.03 Ncm with shaft dia. 6 mm resp 1/4"

Sense of rotation of the drive shaft:

Programmable for sense of rotation clockwise or counterclockwise

Measuring output

Power supply:

H = 12 to 33 V DC (possible with standard version, non-Ex)

H = 12 to **30 V DC** (necessary with Ex-version, type of protection "intrinsically safe" EEx ia IIC T6)

Protected against wrong polarity

Output variable I_A :

Load-independent DC current, proportional to the input angle

Zero point correction:

Approx. ± 5%

Span adjustment:

Approx. ± 5%

Current limitation:

I_A max. 40 mA

Standard range:

4...20 mA, two-wire

External resistance (load):

$$R_{\text{ext max.}} [\text{k}\Omega] = \frac{H [\text{V}] - 12 \text{ V}}{I_A [\text{mA}]}$$

H = DC power supply

I_A = End value of output variable

Load max. [Ω] with output 20 mA

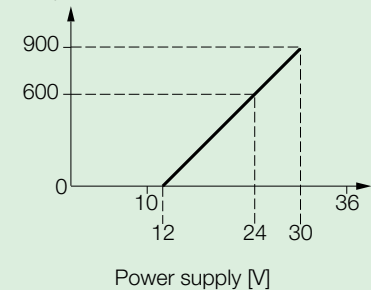

Residual ripple in output current:

< 0.3% p.p.

Response time:

< 5 ms

Programming connector

Interface:

Serial interface

Accuracy data

Reference value:

Measuring span

Basic accuracy:

Error limits at reference conditions $\leq \pm 0.5\%$

Reproducibility:

< 0.2%

Reference conditions

Ambient temperature

23 °C ± 2 K

Power supply

18 V DC

Programmable Transmitter for Angular Position

Output burden	0 Ω	Influence effects (maxima) (included in basic error)	
Adjustments	350° version measuring range > 50...350° characteristic linear	Dependence on external resistance Δ R _{ext} max.	± 0.1%
	50° version measuring range ≥ 10...50° characteristic linear	Power supply influence	± 0.1%
		Additional error (maxima)	
		Temperature influence (- 25...+ 75 °C)	± 0.2% / 10 K
		Bearing play influence	± 0.1%

Additional errors (cumulative)

Output characteristic	Definitions	Device version	Additional error
simple "V" characteristic 	Angle max. = MW Angle min. = 0°	350°	$f = \left(\frac{0.18^\circ}{MW} \times 100 \right)$
		50°	$f = \left(\frac{0.05^\circ}{MW} \times 100 \right)$
"V" characteristic with offset 	MS = (angle max.) - (angle min.) Angle max. = ± final angle Angle min. = > 0°	350°	$f = \left(\frac{0.25^\circ}{MW} \times 100 \right)$
		50°	$f = \left(\frac{0.09^\circ}{MW} \times 100 \right)$
any characteristic 	MS = (angle max.) - (angle min.)	350°	$f = \left(\frac{0.25^\circ}{MW} \times 100 \right)$
		50°	$f = \left(\frac{0.09^\circ}{MW} \times 100 \right)$

KINAX 2W2

Programmable Transmitter for Angular Position

Installation data

Dimensions:	See section "Dimensional drawings"
Housing:	Chromated aluminium
Mounting position:	Any
Electrical connections:	Soldering terminals resp. screw terminals Protection class IP 00 acc. to IEC 529
Permissible vibrations:	5 g every 2 h in 3 directions $f \leq 200$ Hz
Shock:	3 x 50 g 10 shocks each in 3 directions
Admissible static loading of shaft:	Drive shafts dia. 2 mm 6 mm
	Sense resp. 1/4"
	radial max. 16 N 83 N
	axial max. 25 N 130 N
Weight:	Approx. 100 g
Fixation:	3 cheesehead screws M3 or with 3 clamps

Intrinsically safe:	Acc. to EN 50 020
Impulse voltage withstand:	1 kV, 1.2/50 μ s, 0.5 Ws IEC 255-4, Cl. II
Housing protection:	IP 50 acc. to IEC 529
Test voltage:	All connections against housing 500 Veff., 50 Hz, 1 min.
Admissible common-mode voltage:	100 V, 50 Hz

Environmental conditions

Climatic rating:	Standard version Temperature -25 to + 75 °C Annual mean relative humidity $\leq 90\%$
	or Version with improved climatic rating Temperature -40 to + 75 °C Annual mean relative humidity $\leq 95\%$
Transportation and storage temperature:	Ex version Tamb max. + 56 °C at T6 resp. + 75 °C at T4
	-40 to 80 °C

Regulations

Electromagnetic compatibility:	The standards DIN EN 50 081-2 and DIN EN 50 082-2 are observed
--------------------------------	----------------------------------------------------------------

Basic configuration

The transmitter KINAX 2W2 is also available already programmed with a **basic** configuration which is especially recommended in cases where the programming data is not known at the time of ordering (see "Table 1: Specification and ordering information" feature 7).

Basic configuration:

Order Code	Mechanical angle range	Measuring range	Switching point	Sense of rotation	Characteristic of output variable
760 - 1111 100	50°	0 ... 50°	55	Clockwise	Linear
760 - 1211 100	350°	0 ... 350°	355°	Clockwise	Linear

Table 1: Specification and ordering information

Description	*Blocking code	No-go with blocking code	Article No./ Feature
KINAX 2W2			760 -
Features, Selection			
1. Version of the transmitter			
Standard, measuring output non intrinsically safe			1
EEx ia IIC T6, CENELEC/ATEX, measuring output intrinsically safe			
2. Mechanical angle range			
Angle range, to 50°			1
Angle range > 50 to 350°			2

KINAX 2W2

Programmable Transmitter for Angular Position

Description	*Blocking code	No-go with blocking code	Article No./ Feature
KINAX 2W2 Order Code 760 - xxxx xxxx xxxx			760 –
Features, Selection			
3. Drive shaft			
Standard, dia. 2 mm at front, length 6 mm			1
Special, dia. 2 mm at front, length 12 mm, dia. 2 mm at rear, length 6 mm			2
Special, dia. 6 mm at front, length 12 mm			3
Special, dia. 6 mm at front, length 12 mm, dia. 2 mm at rear, length 6 mm			4
Special, dia. 1/4", length 12 mm			5
Special, dia. 1/4", length 12 mm, dia. 2 mm at rear, length 6 mm			6
4. Output variable			
Current, 4 ... 20 mA, 2-wire connection			1
5. Electrical connection			
Connection to soldering terminals			1
Connection to screw terminals			2
6. Test certificate			
Without test certificate			0
Test certificate in German			D
Test certificate in English			E
7. Configuration			
Basic configuration programmed (specification complete!)	G		0
Programmed to order			1
Programmed to order, with zero position mark on the drive shaft disk Required if the device is to be installed without 2W2 software.			2
8. Sense of rotation			
Programmed for sense of rotation clockwise	J		0
Programmed for sense of rotation counterclockwise	J	G	1
Programmed for "V" characteristic	K	G	2
9. Measuring range			
[° angle] 0 ... final value Switching point: 		K	9
Admissible values: Final value: ≥ 10 to 50° with selected angle range 50° > 50 to 350° with selected angle range 350° Switching point: $>$ Final value, max. 60° with angle range 50° $>$ Final value, max. 360° with angle range 350° $\geq 105\%$ final value with non-linear characteristic			
"V" characteristic [\pm° angle] Min. Max. 		GJ	Z
Admissible values: Minimum value: [\pm° angle] ≥ 0 Maximum value [\pm° angle] $\leq 25^\circ$ with angle range 50° , span (max. – min.) $\geq 5^\circ$ $> 25^\circ$ to 175° with angle range 350° , span $\geq 25^\circ$ symmetrical about the center line, e.g. [\pm° angle], min. value = 15; max. value = 120, $\hat{=}$ – 120 ... – 15 ... 0 ... 15 ... 120° (input) and + 20 ... 4 ... $<$ 4 ... 4 ... + 20 mA (output)		GDO	3

KINAX 2W2

Programmable Transmitter for Angular Position

Description	*Blocking code	No-go with blocking code	Article No./ Feature
KINAX 2W2	Order Code 760 - xxxx xxxx xxxx		760 -
Features, Selection			
10. Characteristic of output variable			
Linear			0
Function X to the power of 1/2		GK	1
Function X to the power of 3/2		GK	2
Function X to the power of 5/2		GK	3
Customized		GK	4
Give an algorithm or fixed points (23 values in 5% steps from - 5% to 105% of the measuring range. Output continuously variable 0 to 100%)			
Lines 1 to 4: Not possible with "V" characteristic (line 2 in feature 8, sense of action)			
11. Climatic rating			
Standard climatic rating (annual mean relative humidity ≤ 90%)			0
Improved climatic rating (annual mean relative humidity ≤ 95%)		G	1
12. Marine version			
Without			0
Version GL ("Germanischer Lloyd")		G	1

* Lines with letter(s) under "No-go" cannot be combined with preceding lines having the same letter under "Blocking code".

Electrical connections

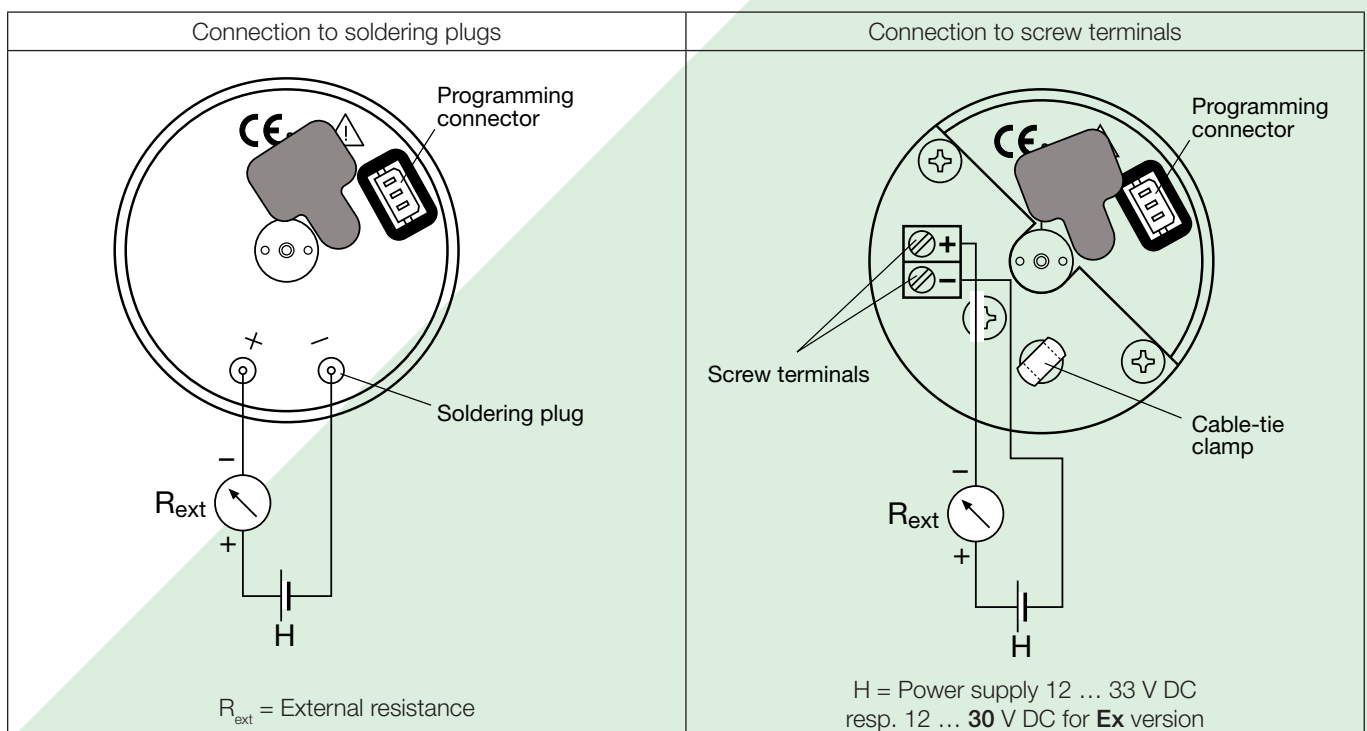

KINAX 2W2

Programmable Transmitter for Angular Position

Table 2: Accessories and spare parts

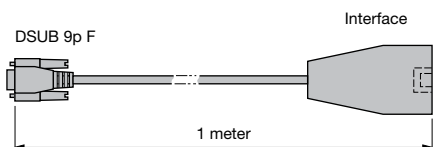
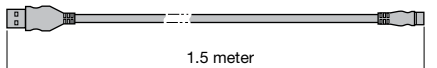
Description	Order No.
Programming cable PK 610 for KINAX 2W2 	137 887
Ancillary cable for KINAX 2W2 	141 440

Description	Order No.
Configuration software 2W2 Windows 95 or higher on CD in German and English (download free of charge under http://www.camillebauer.com) In addition, the CD contains all configuration programmes presently available for Camille Bauer products	146 557
Operating Instructions 2W2 in German	149 965
Operating Instructions 2W2 in French	149 981
Operating Instructions 2W2 in English	149 973

Table 3: Data on explosion protection

Order Code	Type of protection "Intrinsic safety"		Certificate	Mounting location
	Instrument	Measuring output		
760 - 2 ...	EEx ia IIC T6	$U_i = 30 \text{ V}$ $I_i = 160 \text{ mA}$ $P_i = \text{max. } 1 \text{ W}$ $C_i = 6.6 \text{ nF}$ $L_i = 0$	Ex-type-examination Certificate ZELM 03 ATEX 0123	Within the hazardous area, Zone 1

Dimensional drawings (the total depth of the screw-terminal version is 43 mm)

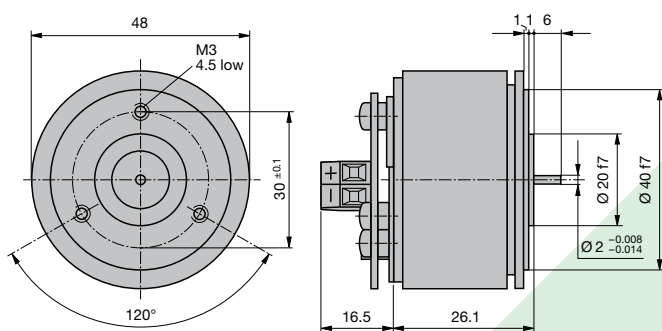

Fig. 6. KINAX 2W2 with standard drive shaft at front **only**, dia. 2 mm, length 6 mm, screw terminal versions

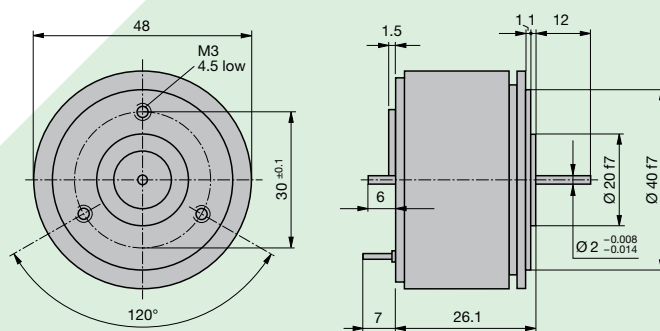

Fig. 7. KINAX 2W2 with special shaft drive at front **and** at rear. At front: dia. 2 mm, length 12 mm. At rear: dia. 2 mm, length 6 mm.

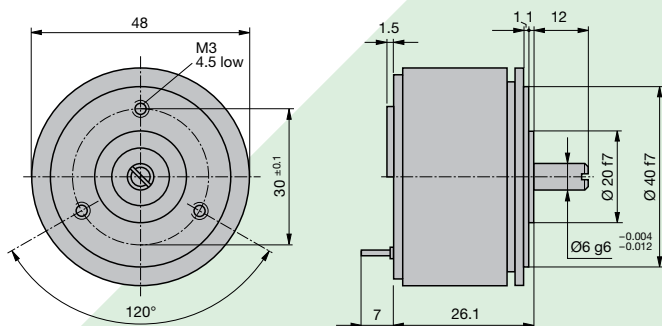

Fig. 8. KINAX 2W2 with special drive shaft at front **only**, dia. 6 mm, length 12 mm.

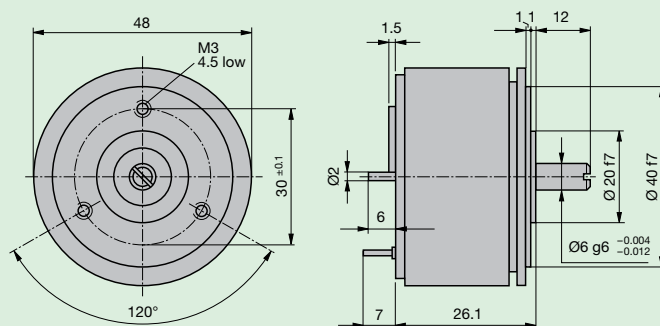

Fig. 9. KINAX 2W2 with special drive shaft at front **and** rear. At front: dia. 6 mm, length 12 mm. At rear dia. 2 mm, length 6 mm.

KINAX 2W2

Programmable Transmitter for Angular Position

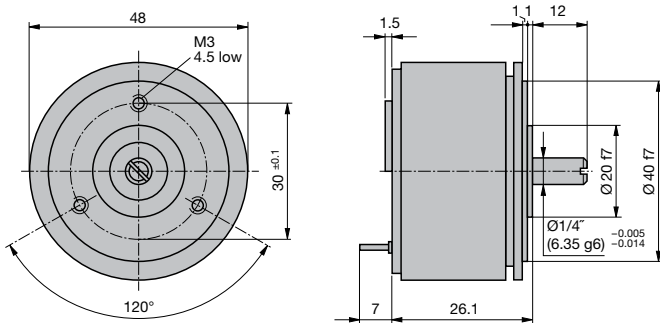

Fig. 10. KINAX 2W2 with special drive shaft at front **only**, dia. 1/4", length 12 mm.

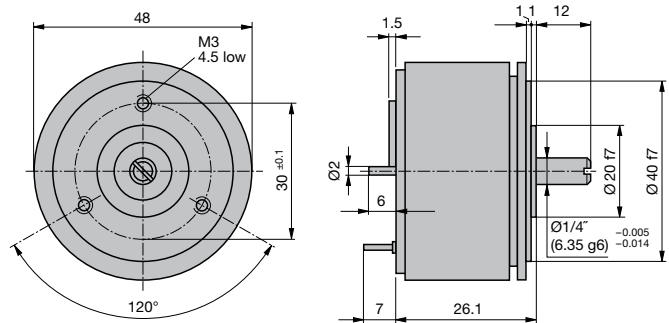

Fig. 11. KINAX 2W2 with special drive shaft at front **and** at rear. At front dia. 1/4", length 12 mm. At rear dia. 2 mm, length 6 mm.

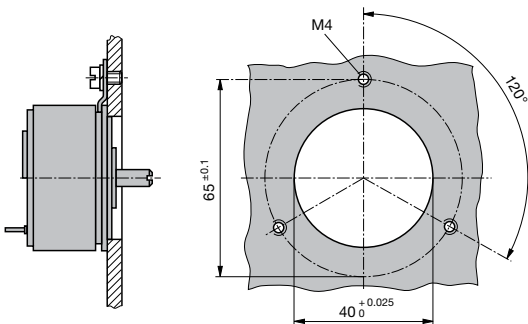

Fig. 12. Drilling plan for fixing with 3 spring clamps.

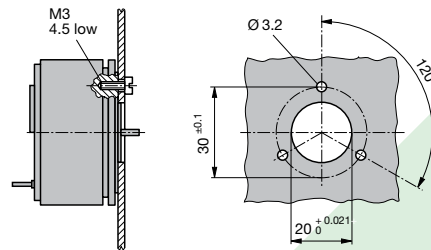

Fig. 13. Drilling plan for fixing with 3 cheesehead M3.

Standard accessories

- 3 clamps
- 1 Operating Instructions each in German, French and English
- 1 Ex-type-examination Certificate (for instruments in Ex version only)

 **CAMILLE BAUER**

Rely on us.

Camille Bauer Ltd
Aargauerstrasse 7
CH-5610 Wohlen / Switzerland

Phone: +41 56 618 21 11

Fax: +41 56 618 35 35

e-mail: info@camillebauer.com

www.camillebauer.com