

SINEAX A 230 / A 230s

Multifunctional Power Monitor with System Analysis

Benefits

- System and load analysis by measurement of harmonics, THD, asymmetry, comprehensive average and max./min. values
- High functionality in a compact form (depth 46 mm) low costs for purchase, engineering and installation
- 4-digit, 14 mm high LED display enables reliable reading from a distance, especially in dark rooms
- User configurable display simplifies local operation

Features

- Accurate meas. values: U, I: 0.2% P, Q, S, PF, meter: 0.5% F: 0.02 Hz
- 4-quadrant measurement of all values in AC systems
- Upgrade extension modules with RS 232/485 interface, load profile memory, MODBUS, synchronizing input, analog output, Ethernet or Profibus-DP
- Safe 3-way galvanic isolation between all circuits
- 2 outputs for pulse or limit values
- 4 meters for active power: Incoming/outgoing with high/low tariff*
- 4 meters for reactive power: Inductive/capacitive or incoming/outgoing with high/low tariff*
- All counter values, recorded values, and settings are kept on a power supply failure
- System/application: Single-phase 3L, balanced/unbalanced (Aron, Full), 4-L balanced/unbalanced (Open-Y, Full)

* Tariff switching with extension module

Application

The display instrument A 230 has dimensions 144 x 144 x 46 mm resp. 96 x 96 x 46 mm for instrument A 230s, and is suitable for mounting in a control panel. With 4-quadrant measurement, it is suitable for system and load analysis in single and multi-phase AC systems.

The A 230/A 230s is designed for application in high, medium and low voltage systems. Any current and voltage transformers are taken into account in the calculation of the measured values.

Display

The measured values are displayed with high contrast by the three 14 mm high LED displays, each with four digits plus sign. The brightness of the display is adjustable. Selectable display modes cover different user requirements. The display settings configured can be archived on the PC for later use. The mode selection can be locked to prevent incorrect operation.

In the FULL mode, the measured values can be displayed without restriction. This aids experts in the assessment of the current situation in the power system.

The number of display windows in USER mode can be reduced to individual requirements by configuration. The USER mode simplifies operation for local personnel.



In LOOP mode, the configured display windows change automatically, in this way, e.g. three voltages and three currents can be displayed alternately. As a further application, the permanent display of a configured display content is possible (preferred display).

All the other display windows can be selected as in FULL mode. After a configurable time interval, the display automatically returns to the preferred display or to LOOP mode

Basic version

Instrument with active and reactive energy counters. Digital outputs configurable as impulse output counters and/or limit value indicators. Comprehensive average value and max./min. value functions. Harmonic analysis and THD measurement. Determination of the neutral wire current, asymmetry factor and neutral point voltage shift.

Extension modules

Extension modules increase the functionality and flexibility. The EMMOD 201 module has an RS 232/RS 485 interface and supports data exchange with a control system via MODBUS RTU. Memory and a digital input (switching between high and low tariffs) for monitoring, or the storage of average power values (load profile) complete the functionality. The user-friendly A200plus software supports parameter setting and reading the measured values.

The EMMOD 202 has 2 galvanically isolated analog outputs. Any of the important input measurements can be assigned to the 4-20 or 0-20 mA signal, and it is possible to program an inverted characteristic.

EMMOD 203 users can communicate with the Ethernet and Internet worlds with the MODBUS over TCP/IP and HTTP. In addition, the module has an extensive memory, which supports backed up recordings for up to one year. The data are recorded with an exact time stamp, which is given by an internal, battery backed up clock.

The EMMOD 204 supplements the functionality as well as the flexibility of the basic device by an Profibus-DP interface.

SINEAX A 230 / A 230s

Multifunctional Power Monitor with System Analysis

All the modules can be upgraded by simply plugging in the extension module without having to open the power monitoring instrument. A separate power supply is not required.

PC software A200plus

Comfortable PC software for the configuration and control of the instrument. Graphic log analysis, measured value display etc. via RS 232 or RS 485/MODBUS-RTU with EMMOD 201 and EMMOD 203.

Variants

Input	Power supply	Special Feature	Order No.	
			A 230	A 230s
500 V, 5 A	85 - 253 V	with EMMOD 201	152 968	---
500 V, 5 A	85 - 253 V		152 942	154 782
500 V, 5 A	85 - 253 V	with test certificate	152 950	154 790
500 V, 5 A	20 - 70 V		152 926	154 766
500 V, 5 A	20 - 70 V	with test certificate	152 934	154 774
500 V, 1 A	85 - 253 V		152 900	154 740
500 V, 1 A	85 - 253 V	with test certificate	152 918	154 758
500 V, 1 A	20 - 70 V		152 885	154 724
500 V, 1 A	20 - 70 V	with test certificate	152 893	154 732
500 V, 5 A	85 - 253 V	with EMMOD 203	155 649	155 657
500 V, 5 A	85 - 253 V	with EMMOD 204	158 651	158 669

Function

The instrument measures the currents I1, I2, I3 and the voltages U1, U2, U3, the frequency, and the phase angles between the individual currents and voltages. All the other measurands are calculated from these. The measurements are made internally via integrated current transformers. Therefore it is possible to make direct connections without an external transformer.

Each input is sampled 32 times per cycle. This allows measurements to be made including up to the 15th harmonic.

The calculation of the measurands is made in accordance with DIN 40 110 part 1 and part 2, however in 4-quadrant operation.

In the figures at this data sheet only SINEAX A 230 is shown. Display and operating are identical with the A 230s.



Bild 1. Blockschema

SINEAX A 230 / A 230s

Multifunctional Power Monitor with System Analysis

Technical data

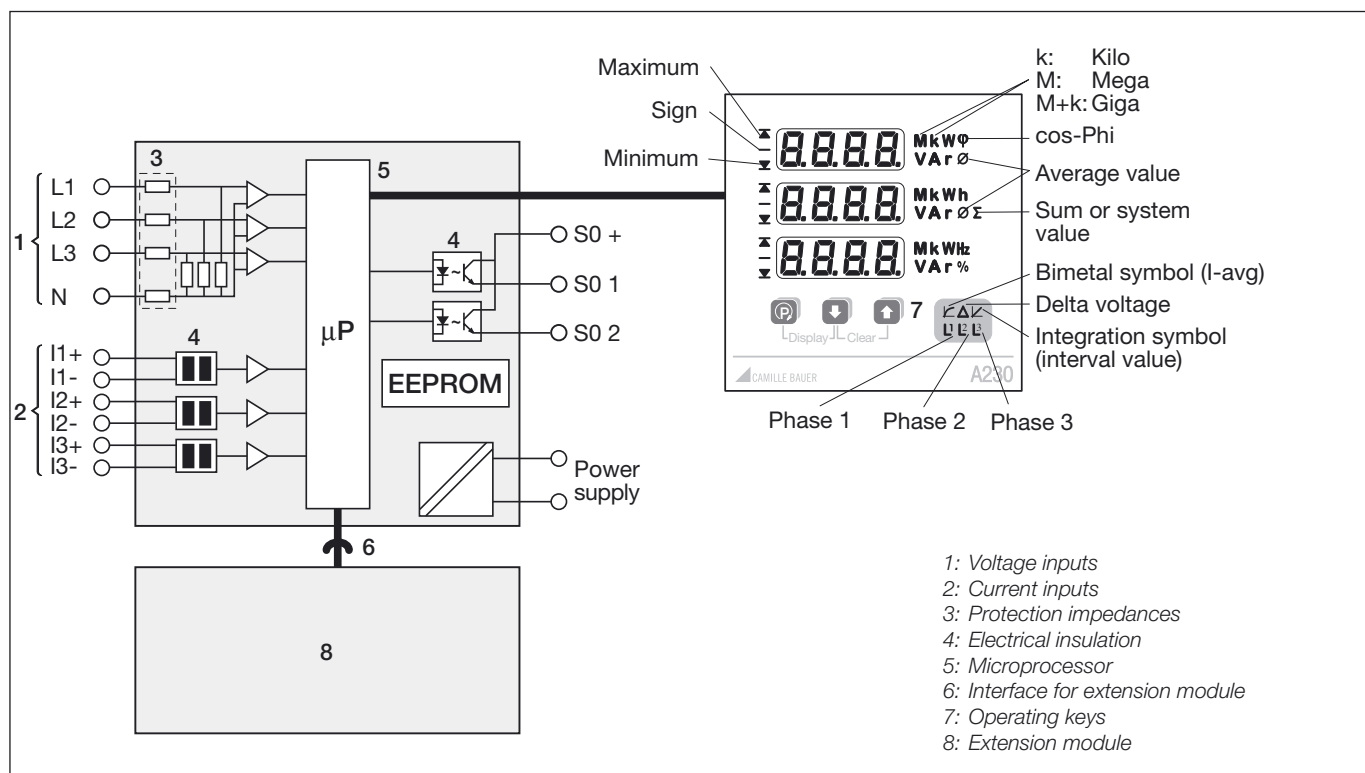
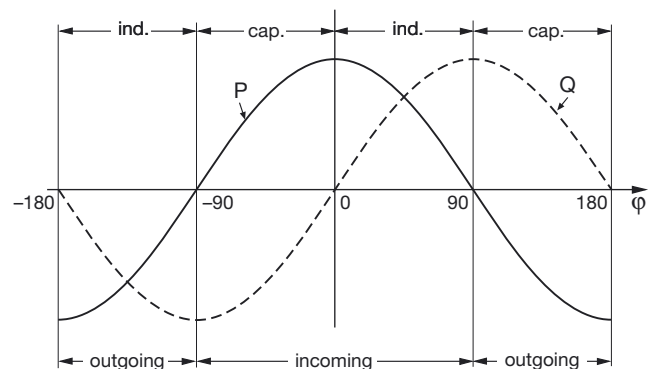
Programmable values (bais instrument)

Connecting mode:	4-wire symmetric and asymmetric load (Open Y, full), 3-wire symmetric and asymmetric load (Aron, full), Single-phase
Voltage transformer:	100 V - 999 kV / 100 V - 999 V
Current transformer:	1.00 A - 999 kA / 1.00 A - 9.99 A
Q definition:	Inductive/capacitive or incoming/outgoing
Digital output:	Off, impulse counters, limit value indicator
Limit value indicator:	Measured value, switch on and off values
Impulse counters:	Measured value, pulse rate
Synchronizing interval:	1 to 30 min.
Display:	Block change ON/OFF, display interval LOOP 2...32 s, display content LOOP and USER mode

Locking the configuration (Jumper Lock)

The configuration can be locked with the jumper, which is at the rear of the instrument (also locks resetting the counters). Nevertheless, the limit values remain adjustable.

Factory default

Jumper:	Not in the LOCK position
Connecting mode:	4-wire asymmetric load
Transformer ratio:	1:1
Q definition:	Inductive/capacitive
Limit value / S01:	Off
Limit value / S02:	Off
Synchronizing interval:	15 min.
Display mode:	FULL, block change off
Brightness:	Mid setting

Deletion of the max./min. values and counters

Both the energy counter values, and the min./max. values can be deleted by pressing a pushbutton twice. The deletion of the counter values can be prevented with the lock jumper (also blocks the configuration).

Data security on power supply failure

All the counter values, recorded values, and settings are kept on a power supply failure.

Applicable regulations and standards

IEC 1010 resp. EN 61010	Safety regulations for electrical measuring, control and laboratory equipment
EN 60 529	Protection types by case
DIN 43 864	Current interface for the transmission of impulses between impulse counter and tariff meter (SO output)

DIN 40 110	AC quantities
IEC/EN 61326-1	Electrical equipment for control and laboratory use, EMV requirements
IEC/EN 61326/A1	Electrical equipment for measurement, control and laboratory use, EMV requirements
IEC/EN 61326/A1	Electrical equipment for measurement, control and laboratory use, EMV requirements, disturbance immunity
EN 60 688	Electrical measuring transducers for converting AC electrical variables into analogue and digital signals
IEC 68-2 resp. EN 60 068-2-1/-2/-3/-6/-27	Ambient tests -1 Cold, -2 Dry heat, -3 Damp heat, -6 Vibration, -27 Shock

Measuring inputs

Nominal frequency:	50, 60 Hz
Nominal voltage:	Phase-phase: 500 V resp. Phase-N: 290 V
Nominal current:	5 A or 1 A
Waveform:	Sine
Own consumption:	Current circuit: $\leq I^2 \cdot 0.01 \Omega$ Voltage circuit: $\leq U_{LN}^2 / 300 \text{ k}\Omega$

Continuous thermal rating of inputs

10 A at 346 V in single-phase AC system
10 A at 600 V in three-phase system

Short-time thermal rating of inputs

Input variable	Number of inputs	Duration of overload	Interval between two overloads
557 V LN	10	1 s	10 s
100 A	10	1 s	100 s
100 A	5	3 s	5 min.

Measuring ranges

U, I, S:	$\leq 120\%$ of nominal value
P, Q:	$\leq \pm 120\%$ of nominal value
F:	45 to 65 Hz
Power factor (cosφ):	± 1
Overload indicator:	oL

The frequency is measured from the current or voltage. The voltage has priority.

Measurements available

Reference conditions acc. to IEC 688 resp. EN 60 688
Sine 50 - 60 Hz, 15 - 30 °C, application group II,
Power supply 230 V AC/DC resp. 24 V AC/DC
The calculation of the measurands is in accordance with DIN 40 110 with 4-quadrant measurement.

SINEAX A 230 / A 230s

Multifunctional Power Monitor with System Analysis

Measured quantity	Measuring path	max	min	Error ¹⁾
Voltage	1N, 2N, 3N	•	•	0.2%
Voltage	12, 23, 31	•	•	0.2%
Voltage average value	Σ	•		0.2%
Voltage	N-E	•		0.2%
Current	1, 2, 3	•		0.2%
Current I _{avg} (bimetal-15min) (slave pointer)	1, 2, 3	•		0.2%
Current average value	Σ	•		0.2%
Neutral current	N	•		0.5%
Active power P	1, 2, 3, Σ	•		0.5%
Reactive power Q	1, 2, 3, Σ	•		0.5%
Apparent power S	1, 2, 3, Σ	•		0.5%
Power factor PF (cosφ 4-quadrant display)	1, 2, 3, Σ			0.5%
PF incoming ind. min.	1, 2, 3		•	0.5%
PF outgoing cap. min.	1, 2, 3		•	0.5%
PF outgoing ind. min.	1, 2, 3		•	0.5%
PF outgoing kap. min.	1, 2, 3		•	0.5%
Frequency	U, I	•	•	0.02 Hz
Active power incoming/outgoing (tariff high and low)	Σ			0.5%
Reactive power incoming/outgoing (tariff high and low)	Σ			0.5%
Reactive power ind./cap. (tariff high and low)	Σ			0.5%
5 active power intervals each incoming/outgoing (+ Trend)	Σ	•	•	0.5%
5 reactive power intervals each incoming/outgoing (+ Trend)	Σ	•	•	0.5%
5 reactive power intervals each inductive/capacitive (+ Trend)	Σ	•	•	0.5%
5 apparent power intervals (+ Trend)	Σ	•	•	0.5%
9 gen. interval average values (+ Trends)	Meas. value	•	•	Meas. value
Voltage asymmetric	Σ	•		0.5%
THD voltage	1N, 2N, 3N	•		1.0%
THD voltage	12, 23, 31	•		1.0%
THD current	1, 2, 3	•		1.0%
2. - 15. harmonic, voltage	1N, 2N, 3N	•		1.0%
2. - 15. harmonic, voltage	12, 23, 31	•		1.0%
2. - 15. harmonic, current	1, 2, 3	•		1.0%

Note

A possible synchronizing signal (extension module) for the interval values must be within the range of 10 sec. to 90 min.

Digital outputs

Depending on the function selected, the two digital outputs can be used either as pulse outputs for actual and reactive energy or as limit signals.

The outputs are passive, and are galvanically isolated from all the other circuits by opto-couplers. They are suitable to drive tariff devices (S0-standard DIN 43 864) or 24 V-relays.

U_{ext} ≤ 40 V DC (OFF: leakage current ≤ 0.1 mA)

I_L ≤ 150 mA (ON: terminal voltage ≤ 1.2 V)

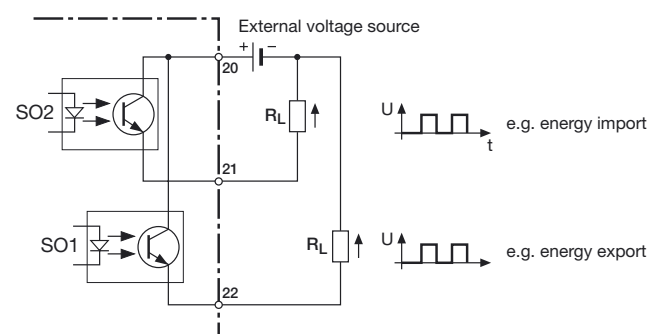

Alarm unit

Limit values can be associated with every measurand, with the exception of harmonic content.

There is a logical OR function for the line value ON limit values, and a logical AND function for the OFF limit values.

3-wire unbalanced load

U₁₂/U₂₃/U₃₁ I₁/I₂/I₃ THD.U₁₂/THD.U₂₃/
THD.U₃₁
I_{avg1}/I_{avg2}/I_{avg3} THD.I₁/THD.I₂/THD.I₃

4-wire unbalanced load

U₁/U₂/U₃ I₁/I₂/I₃ THD.U_{1N}/THD.U_{2N}/
THD.U_{3N}
U₁₂/U₂₃/U₃₁ I_{avg1}/I_{avg2}/I_{avg3} THD.I₁/THD.I₂/THD.I₃
P₁/P₂/P₃ Q₁/Q₂/Q₃ S₁/S₂/S₃
PF₁/PF₂/PF₃

Example 1 (ON-limit value > OFF-limit value)

Output "ON": immediately one of the 3 phase currents exceeds the ON limit value

Output "OFF": when all the phase currents go below the OFF limit value

Example 2 (ON-limit value < OFF-limit value)

Output "ON": immediately one of the 3 phase currents goes below the ON limit value

Output "OFF": when all the phase currents exceed the OFF limit value

Delay time: 1 s (cannot be programmed)

¹⁾ Error ± related to nominal value (frequency = absolute)
Σ = System value

SINEAX A 230 / A 230s

Multifunctional Power Monitor with System Analysis

Pulse outputs

The reactive and active energy can be read out at the pulse outputs in the form of standard SO pulses for the driving of electronic and electromechanical counting mechanisms. For systems with external transformers, the pulses are for the primary energy data.

Pulse rate:	1 ... 5000 Imp./Wh ... GWh 1 ... 5000 Imp./varh ... Gvarh
Pulse duration:	≥ 100 ms (cannot be programmed)

Power supply

DC, AC power pack 45 to 400 Hz
85 to 253 V AC/DC or
20 to 70 V AC/DC

Power consumption:	< 3 VA (without extension module)
--------------------	-----------------------------------

Display

LED digital display:	14 mm high, red
LED symbols:	5 mm high, red
Brightness:	adjustable
Measured values:	4 digits with sign
Energy counters:	8 digit (top + middle display)

Zero value suppression

PF resp. $\cos\phi$:	Display ---, if $S_x < 0.2\% S_{nenn}$
Currents:	Display 0, if $I_x < 0.1\% I_{nenn}$
unb. U:	Display 0, if $\emptyset U < 5\% U_{nenn}$

Safety

Protection class:	II (voltage inputs with protection impedances)
Measuring category:	III
Pollution degree:	2
Measurement voltage:	300 V
Test voltage:	Between current inputs, power supply, digital outputs, terminals of the plugged-in module: 3700 V / 50 Hz / 1 min. On voltage inputs: 4.25 kV 1.2/50 μ s
Module connections:	The pin rail at the back is connected to the voltage inputs via a protection impedance. Only the permitted modules can be plugged-in!
Enclosure protection:	Front IP 66, terminals IP 20

Inputs, outputs and power supply are electrically isolated. The current inputs are electrically isolated from each other.

Mechanic

Dimensions	A 230:	144 x 144 x 46 mm; panel cutout 138 ⁺¹ x 138 ⁺¹ mm
	A 230s:	96 x 96 x 46 mm; panel cutout 92 ^{+0,8} x 92 ^{+0,8} mm

Housing material:	ABS flammability class V-0 acc. to UL94, self-extinguishing, non-dripping, free of halogen
Weight:	300 g at A 230 resp. 250 g at A 230s
Mounting:	For control panel mounting
Terminals:	
Inputs:	Screw terminals wire gauge single wire: 0.5 - 2.5 mm ² wire gauge fine wire: 0.5 - 1.5 mm ²
Power supply, outputs:	Spring clamps Wire gauge single and fine wire: 0.5 - 1.5 mm ²

Environmental conditions

Operating temperature:	- 10 to + 55 °C
Storage temperature:	- 25 to + 70 °C
Humidity relative:	≤ 75%
Altitude:	2000 m max.
Indoor use statement	

Note of maintenance

No maintenance is required

SINEAX A 230 / A 230s

Multifunctional Power Monitor with System Analysis

Display possibilities for 4-wire asymmetrical load connection

		a	b	c	d	e	f	g	h						
1	U1 U2 U3	U1 ▲ U2 ▲ U3 ▲	U1 ▼ U2 ▼ U3 ▼	U12 U23 U31	U12 ▲ U23 ▲ U31 ▲	U12 ▼ U23 ▼ U31 ▼	UNE UNE ▲	unb. U unb. U ▲							
2	I1 I2 I3	I1 ▲ I2 ▲ I3 ▲	I1avg I2avg I3avg	I1avg ▲ I2avg ▲ I3avg ▲	IN IN ▲										
3	P1 P2 P3	P1 ▲ P2 ▲ P3 ▲	P P ▲												
4	Q1 Q2 Q3	Q1 ▲ Q2 ▲ Q3 ▲	Q Q ▲												
5	S1 S2 S3	S1 ▲ S2 ▲ S3 ▲	S S ▲												
6	PF1 PF2 PF3	PF PF ▼-inc-ind PF ▼-inc-cp	PF PF ▼-out-ind PF ▼-out-cp												
7	F ▲ F F ▼														
8	EP inc HT	EP inc LT	EP out HT	EP out LT											
9	EQ inc/ind HT	EQ inc/ind LT	EQ out/cap HT	EQ out/cap LT											
10	P Q S	U Ø I Ø P	PF P Q	P S F											
11	P1 Q1 S1	P2 Q2 S2	P3 Q3 S2	U1 I1 P1	U2 I2 P2	U3 I3 P3									
12	thd.U1 thd.U1 ▲	thd.U2 thd.U2 ▲	thd.U3 thd.U3 ▲												
13	thd.I1 thd.I1 ▲	thd.I2 thd.I2 ▲	thd.I3 thd.I3 ▲												
14	P.inc-int-Trend	P.inc-int- ▲ P.inc-int- ▼	P.inc-int t-0	P.inc-int t-1	P.inc-int t-2	P.inc-int t-3	P.inc-int t-4								
15	P.out-int-Trend	P.out-int- ▲ P.out-int- ▼	P.out-int t-0	P.out-int t-1	P.out-int t-2	P.out-int t-3	P.out-int t-4								
16	Q.inc/ind-int-Trend	Q.inc/ind-int- ▲ Q.inc/ind-int- ▼	Q.inc/ind-int t-0	Q.inc/ind-int t-1	Q.inc/ind-int t-2	Q.inc/ind-int t-3	Q.inc/ind-int t-4								
17	Q.out/cap-int-Trend	Q.out/cap-int- ▲ Q.out/cap-int- ▼	Q.out/cap-int t-0	Q.out/cap-int t-1	Q.out/cap-int t-2	Q.out/cap-int t-3	Q.out/cap-int t-4								
18	S.int-Trend	S.int- ▲ S.int- ▼	S.int t-0	S.int t-1	S.int t-2	S.int t-3	S.int t-4								
		a	b	c	d	e	f	g	h	i	j	k	l	m	n
19	H2.U1 H2 ▲.U1	H3.U1 H3 ▲.U1	H4.U1 H4 ▲.U1	H5.U1 H5 ▲.U1	H6.U1 H6 ▲.U1	H7.U1 H7 ▲.U1	H8.U1 H8 ▲.U1	H9.U1 H9 ▲.U1	H10.U1 H10 ▲.U1	H11.U1 H11 ▲.U1	H12.U1 H12 ▲.U1	H13.U1 H13 ▲.U1	H14.U1 H14 ▲.U1	H15.U1 H15 ▲.U1	
20	H2.U2 H2 ▲.U2	H3.U2 H3 ▲.U2	H4.U2 H4 ▲.U2	H5.U2 H5 ▲.U2	H6.U2 H6 ▲.U2	H7.U2 H7 ▲.U2	H8.U2 H8 ▲.U2	H9.U2 H9 ▲.U2	H10.U2 H10 ▲.U2	H11.U2 H11 ▲.U2	H12.U2 H12 ▲.U2	H13.U2 H13 ▲.U2	H14.U2 H14 ▲.U2	H15.U2 H15 ▲.U2	
21	H2.U3 H2 ▲.U3	H3.U3 H3 ▲.U3	H4.U3 H4 ▲.U3	H5.U3 H5 ▲.U3	H6.U3 H6 ▲.U3	H7.U3 H7 ▲.U3	H8.U3 H8 ▲.U3	H9.U3 H9 ▲.U3	H10.U3 H10 ▲.U3	H11.U3 H11 ▲.U3	H12.U3 H12 ▲.U3	H13.U3 H13 ▲.U3	H14.U3 H14 ▲.U3	H15.U3 H15 ▲.U3	
22	H2.I1 H2 ▲.I1	H3.I1 H3 ▲.I1	H4.I1 H4 ▲.I1	H5.I1 H5 ▲.I1	H6.I1 H6 ▲.I1	H7.I1 H7 ▲.I1	H8.I1 H8 ▲.I1	H9.I1 H9 ▲.I1	H10.I1 H10 ▲.I1	H11.I1 H11 ▲.I1	H12.I1 H12 ▲.I1	H13.I1 H13 ▲.I1	H14.I1 H14 ▲.I1	H15.I1 H15 ▲.I1	
23	H2.I2 H2 ▲.I2	H3.I2 H3 ▲.I2	H4.I2 H4 ▲.I2	H5.I2 H5 ▲.I2	H6.I2 H6 ▲.I2	H7.I2 H7 ▲.I2	H8.I2 H8 ▲.I2	H9.I2 H9 ▲.I2	H10.I2 H10 ▲.I2	H11.I2 H11 ▲.I2	H12.I2 H12 ▲.I2	H13.I2 H13 ▲.I2	H14.I2 H14 ▲.I2	H15.I2 H15 ▲.I2	
24	H2.I3 H2 ▲.I3	H3.I3 H3 ▲.I3	H4.I3 H4 ▲.I3	H5.I3 H5 ▲.I3	H6.I3 H6 ▲.I3	H7.I3 H7 ▲.I3	H8.I3 H8 ▲.I3	H9.I3 H9 ▲.I3	H10.I3 H10 ▲.I3	H11.I3 H11 ▲.I3	H12.I3 H12 ▲.I3	H13.I3 H13 ▲.I3	H14.I3 H14 ▲.I3	H15.I3 H15 ▲.I3	

Q meas. values are in italics: depending on the Q definition, either the values for incoming/outgoing or the values for ind./cap. are displayed.





▲ Maximal value



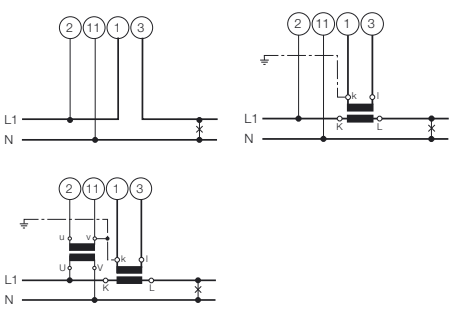

▼ Minimal value

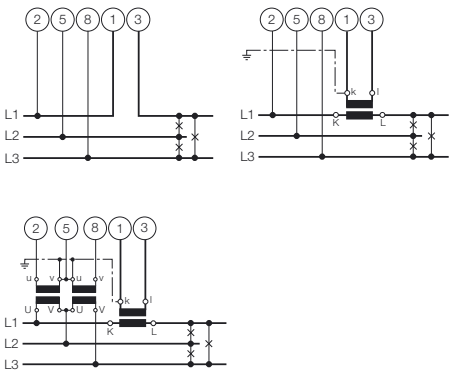
SINEAX A 230 / A 230s

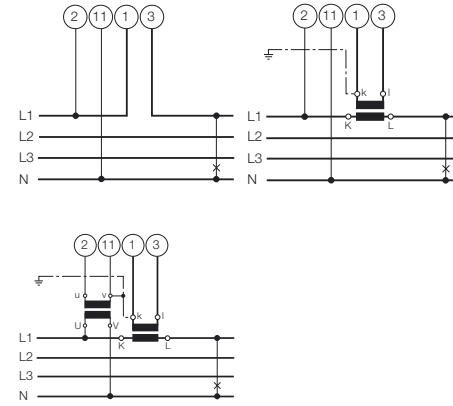
Multifunctional Power Monitor with System Analysis

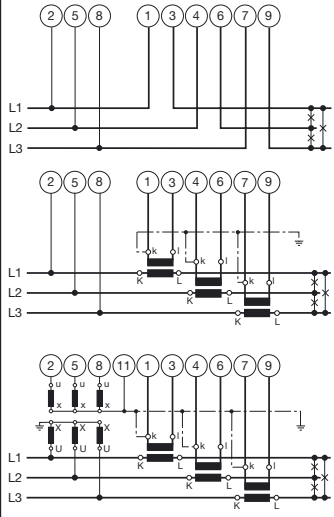
Connection modes

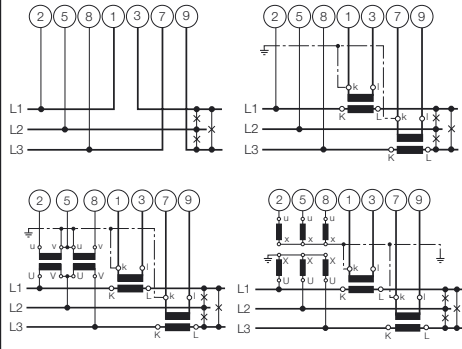
System/ application	Terminals																	
Single phase AC system 																		
3-wire 3-phase symmetric load I: L1 	 <p>Connect the voltage according to the following table for current measurement in L2 or L3:</p> <table border="1"> <thead> <tr> <th>Current transf.</th> <th>Terminals</th> <th>2</th> <th>5</th> <th>8</th> </tr> </thead> <tbody> <tr> <td>L2</td> <td>1</td> <td>3</td> <td>L2</td> <td>L3</td> <td>L1</td> </tr> <tr> <td>L3</td> <td>1</td> <td>3</td> <td>L3</td> <td>L1</td> <td>L2</td> </tr> </tbody> </table>	Current transf.	Terminals	2	5	8	L2	1	3	L2	L3	L1	L3	1	3	L3	L1	L2
Current transf.	Terminals	2	5	8														
L2	1	3	L2	L3	L1													
L3	1	3	L3	L1	L2													
4-wire 3-phase symmetric load I: L1 	 <p>Connect the voltage according to the following table for current measurement in L2 or L3:</p> <table border="1"> <thead> <tr> <th>Current transf.</th> <th>Terminals</th> <th>2</th> <th>11</th> </tr> </thead> <tbody> <tr> <td>L2</td> <td>1</td> <td>3</td> <td>L2</td> <td>N</td> </tr> <tr> <td>L3</td> <td>1</td> <td>3</td> <td>L3</td> <td>N</td> </tr> </tbody> </table>	Current transf.	Terminals	2	11	L2	1	3	L2	N	L3	1	3	L3	N			
Current transf.	Terminals	2	11															
L2	1	3	L2	N														
L3	1	3	L3	N														

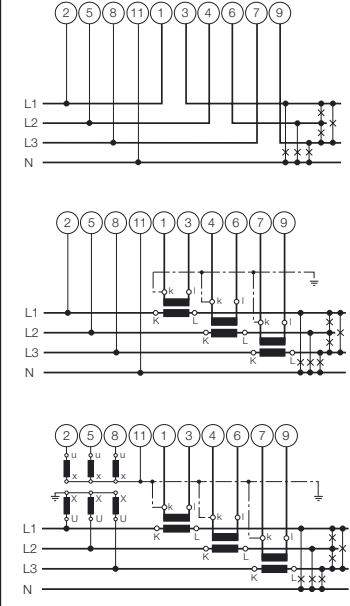
System/ application	Terminals
3-wire 3-phase asymmetric load 	 <p>3 single-pole insulated voltage transformers in high-voltage system</p>
3-wire 3-phase asymmetric load Aron 	
4-wire 3-phase asymmetric load 	 <p>3 single-pole insulated voltage transformers in high-voltage system</p>

SINEAX A 230 / A 230s

Multifunctional Power Monitor with System Analysis

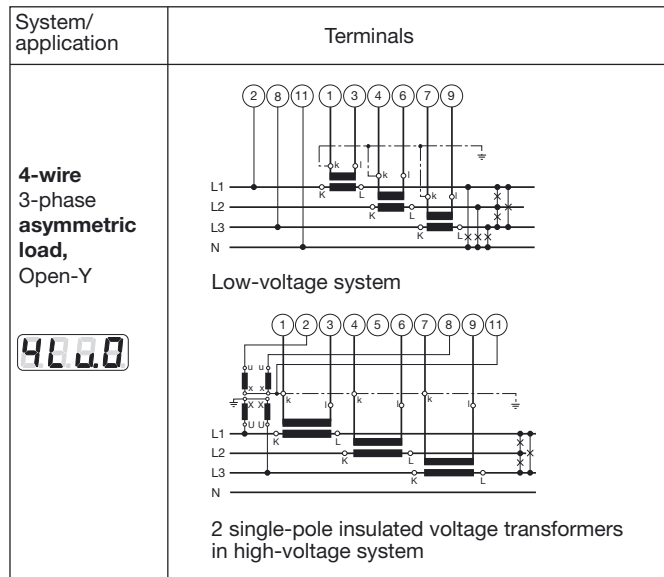

SINEAX A 230s

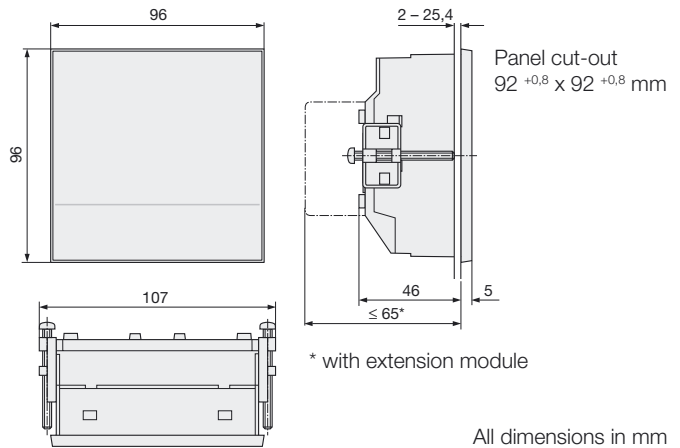

PC software A200plus*)

Connection via the extension module. Comfortable PC software for the configuration, control, display of measured values, graphic logger analysis etc.

Electrical connections

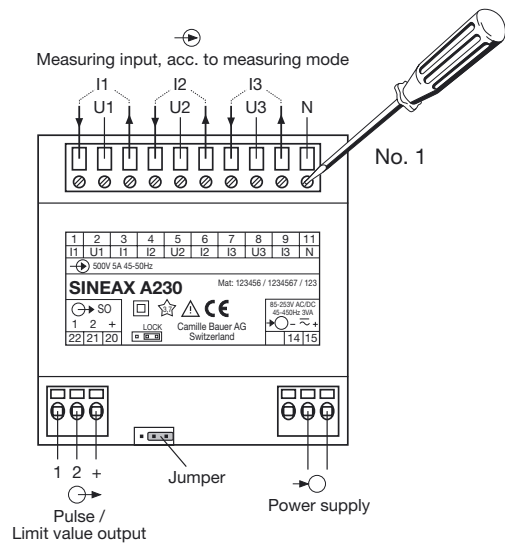

Scope of supply

- A 230 resp. A 230s without extension module
- Operating Instructions in German, French and English
- Fixing clamp
- Test certificate for the corresponding variant

Accessories SINEAX A 230/A 230s

Description	Article No.
Operating Instructions *) in German	152 851
Operating Instructions *) in French	154 815
Operating Instructions *) in English	154 807
Top-hat rail adapter	154 055
Fixing clips as set (4 pce.) for top-hat rail adapter with extension module	154 394
Extension module EMMOD 201 Interface/MODBUS RTU/Data logger	150 285
Extension module EMMOD 202 2 analog outputs	155 574
Extension module EMMOD 203 Ethernet, 2 MB memory, real-time clock	155 582
Extension module EMMOD 204 Profibus-DP	158 510

Dimensional drawings

SINEAX A 230

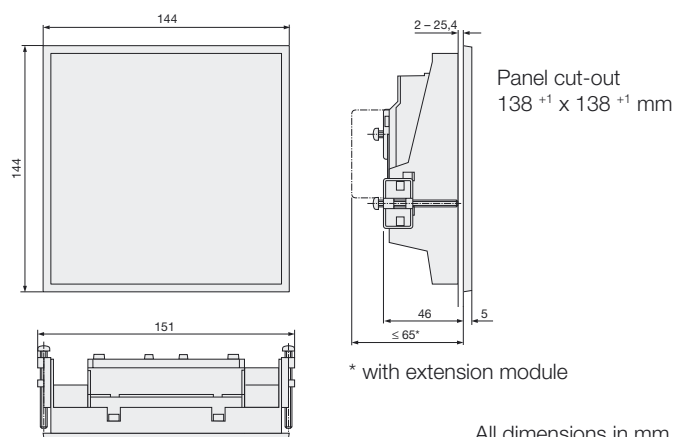

Extension module EMMOD 201

Communication

Interface: RS232/RS485 switchable

*) Download free of charge under www.camillebauer.com

SINEAX A 230 / A 230s

Multifunctional Power Monitor with System Analysis

Protocol: MODBUS RTU for SCADA

Digital input: Synchronizing signal for average power values or high/low tariff switchover for energy counters

Bus address: 1 to 247

Baudrate: 1200, 2400, 4800, 9600, 19.2 k

Parity check: no, even, odd, space

Recording average power value

Values that can be recorded:

Pint: active power average value with sign (incoming + / outgoing -)

Qint: reactive power average value (inductive + / capacitive -)

Amount of data at 15 min intervals:

1 value (Pint or Qint) = 166 days

2 value (Pint and Qint) = 83 days

Accessories EMMOD 201 (not included in scope of supply)

Description	Article No.
Software A200plus *)	146 557
Interface adapter cable	152 603
Extension cable sub-D 9pol. 2 m	980 179

Dimensional drawing

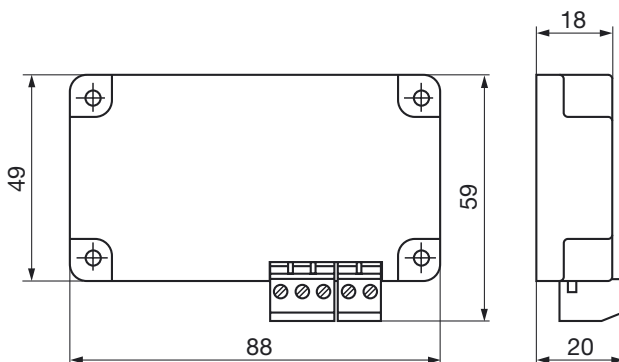

Extension module EMMOD 202

Input: U, I, lavg, In, P, Q, S, F, cosφ

Output: 0 - 20 mA, 4 - 20 mA, inverting

Limits: 0/3.7 mA resp. 21 mA

Burden voltage: 8 V

Accuracy: 0.1% (without A2..)

Number of channels: 2 (electrically isolated)

Dimensional drawing

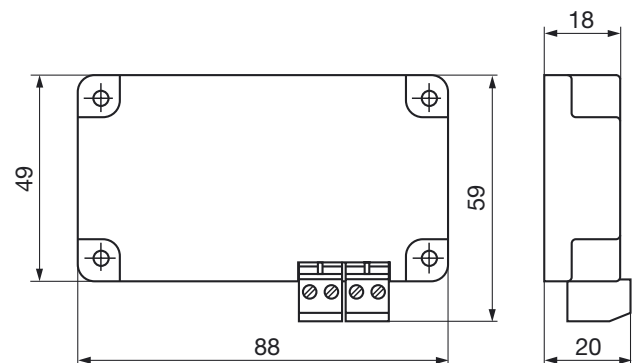

Extension module EMMOD 203

Protocol: MODBUS over TCP/IP, HTTP

Real-time clock: Battery backup, synchronized via LAN or external (e.g. 230 V/50 Hz)

Memory: up to one year with time stamp

Connections

Ethernet RJ45 port: 10/100 base Tx

Tariff switching: plug-in screw terminals

Synchronizing input: plug-in screw terminals

Synchronizing input: 5 V – 300 V AC, 1 – 500 Hz

Tariff switching: 5 V – 300 V AC/DC

Dimensional drawing

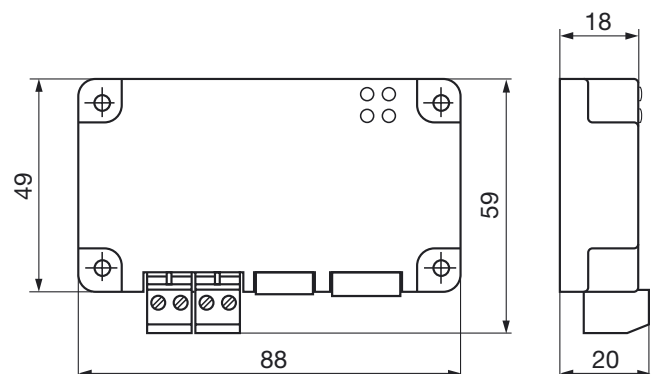

Accessories EMMOD 203 (not included in scope of supply)

Description	Art.-No.
Software A200plus *)	146 557

*) Download free of charge under <http://www.camillebauer.com>

SINEAX A 230 / A 230s

Multifunctional Power Monitor with System Analysis

Extension module EMMOD 204

Interface: Profibus-DP
9-pin D-sub socket
EIA RS485 standard
15 kV ESD protection

Baudrate: Autom. recognition,
9600 bit/s ... 12 Mbit/s

Type: DPV0, SPC4-2
Repeater_Ctrl_Sig (TTL)

Address: 126 (0 - 125)
Set_Slave_Add_Supp

Dimensional drawing

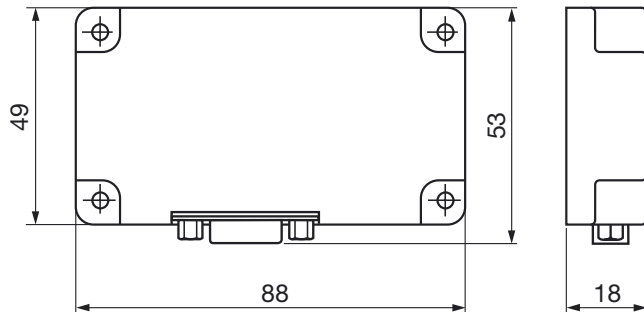

Accessories EMMOD 204 (not included in scope of supply)

Description	Article No.
Device Master File (DMF *)	150 764

*) Download free of charge under <http://www.camillebauer.com>